

TRF416

TAMIYA RACING FACTORY

CHASSIS KIT
1/10 SCALE R/C 4WD RACING CAR
TRF416 CHASSIS KIT

SETTING SHEET

Name **Ed Clark** Date **02/03/08** Air Temp. _____ Humidity _____
Track **IoWRCCC - Start** Track Condition **Mid - High** Track Temp _____

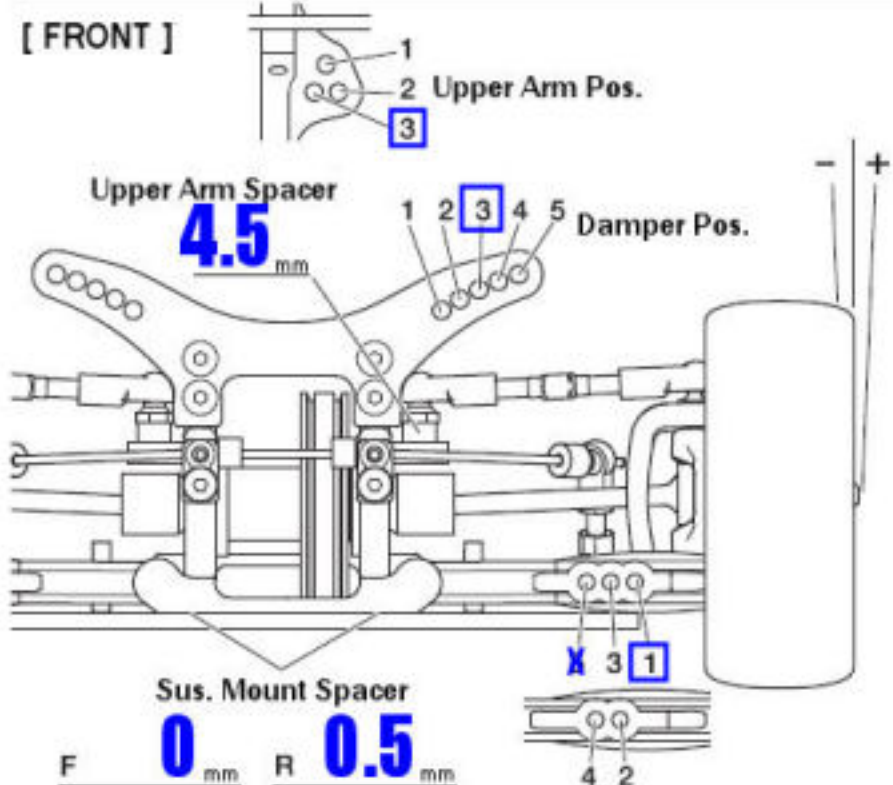

Caster Blocks	2' 4 '
Camber	1.5 °
Ride Height	5 mm
Droop	#5 mm
Front Axle	One-way _____ Diff Spool
Roll bar	None S M H
Wheel Spacer	0 mm

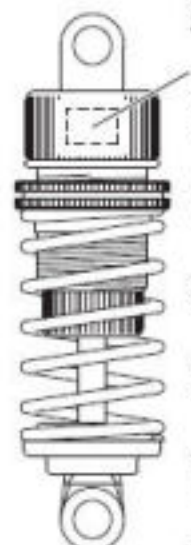

Shock Bushing	0 Piece(s)
Piston	3 Holes
Oil	450 Weight
Spring	Tam White
Shock Length	61.1 mm
Wheel Hex	5 mm
Rebound	2mm %

Notes
Short LWT arms, Droop on gauge

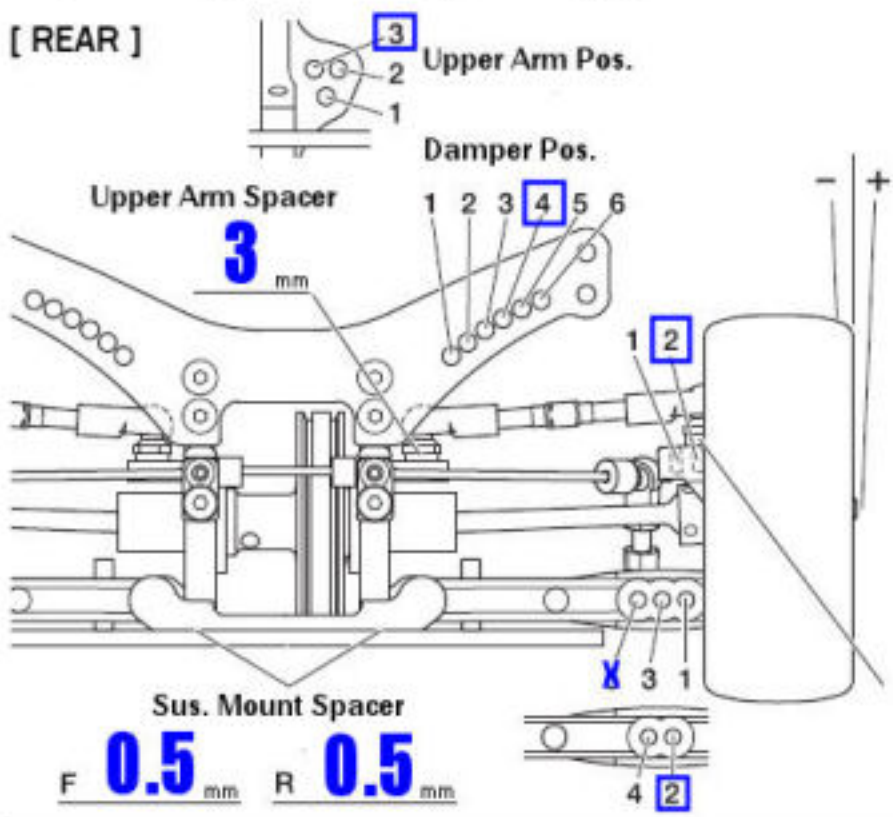

Rear Hub	0 °
Camber	2 °
Ride Height	5.5 mm
Droop	#4 mm
Roll bar	None S M H
Wheel Spacer	0 mm
Upper Arm Spacer	2 mm



Shock Bushing	0 Piece(s)
Piston	3 Holes
Oil	550 Weight
Spring	Tam Blue
Shock Length	61.1 mm
Wheel Hex	5 mm
Rebound	2mm %

LRP Sphere Settings; 1, 4, 0, 2

Toe Angle **0** ° F Sus. Mount F **D** R **D** R Sus. Mount F **XA** R **E**

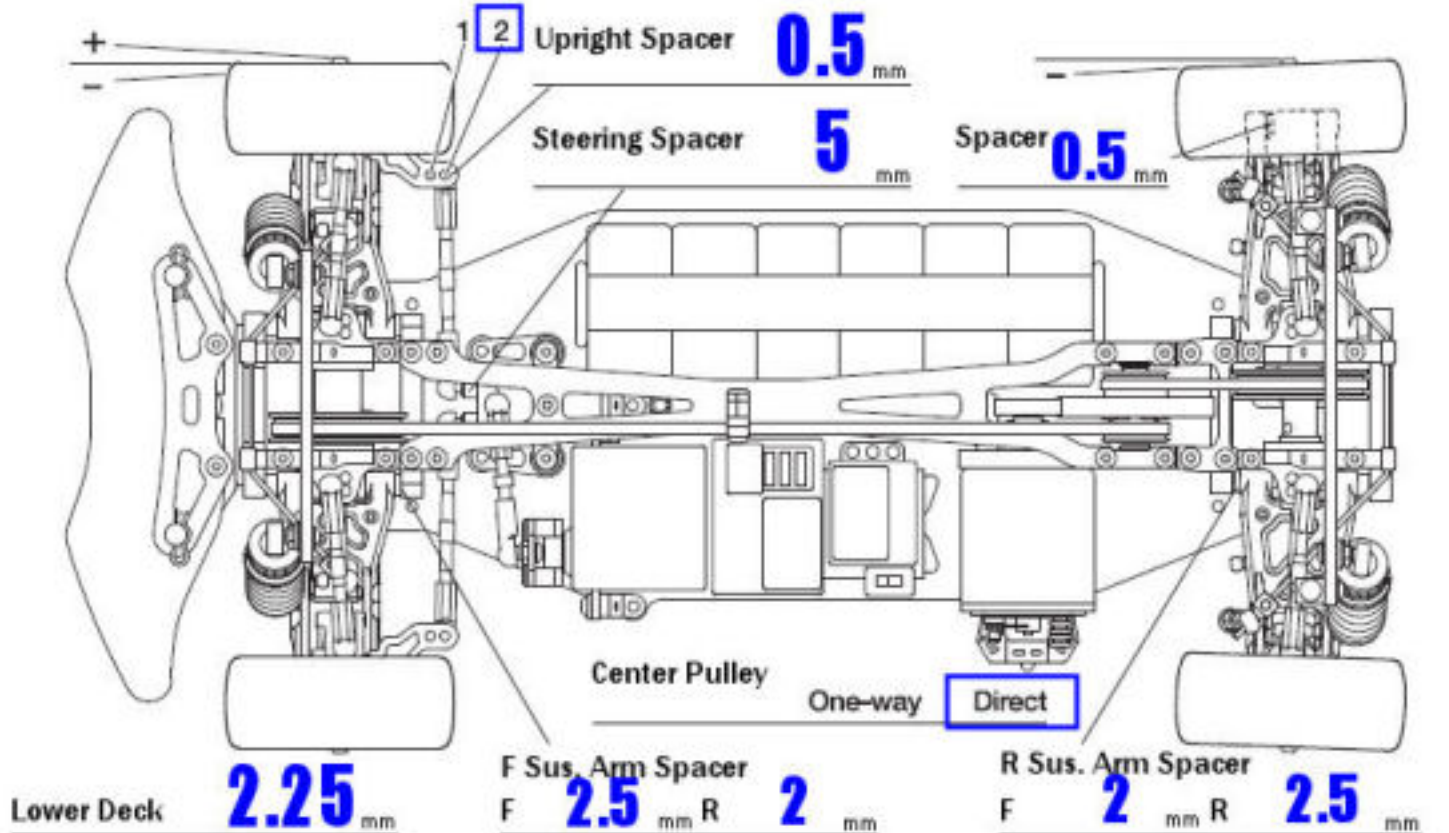

Motor **Orion 10.5**
Spur **106** T Pinion **38** T
Battery **Carbon 3600**
Body **Mazda 6**
Wing _____
Tire _____
Wheel **Vtec 30R**
Insert _____
Best Lap _____