

TRF415

SETTING SHEET [Standard Arms]

Name **Ed Clark** Date **12-12-04** Air Temp. _____ Humidity _____
 Track **Don Valley BIWS Rd2** Track Cond. _____ Track Temp. _____

[Front]

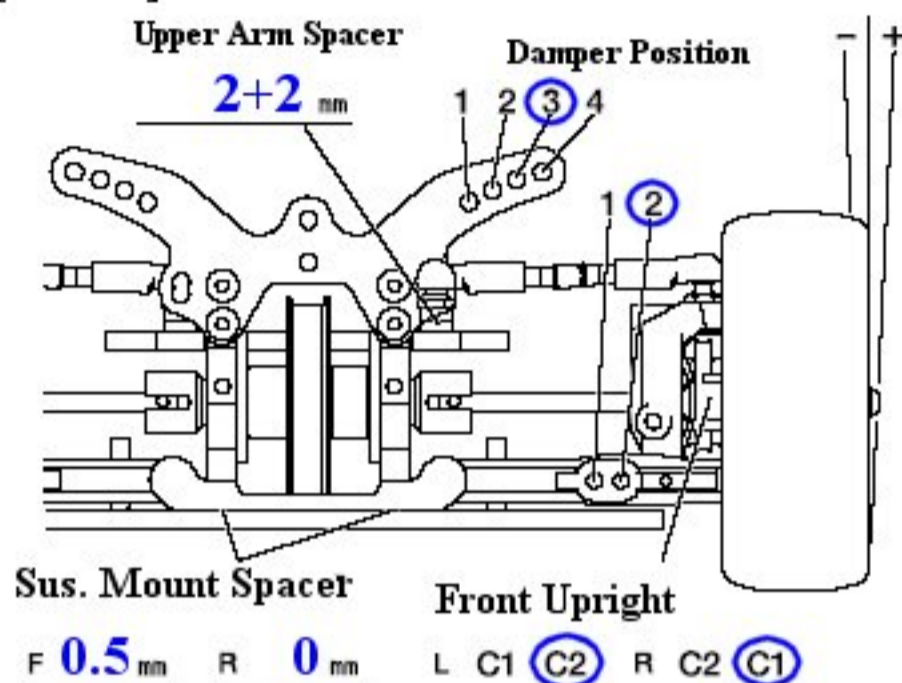

Camber	2°
Ride Height	5 mm
Droop	#4 mm
Front Drive Spool Diff	One-way
Roll Bar	None S M H
Notes	



Shock Length	62.0 mm
Piston	3 holes
Oil	50 wt.
Spring	Blue
Wheel Hex	6 mm
Wheel Spacer	0 mm

[Rear]

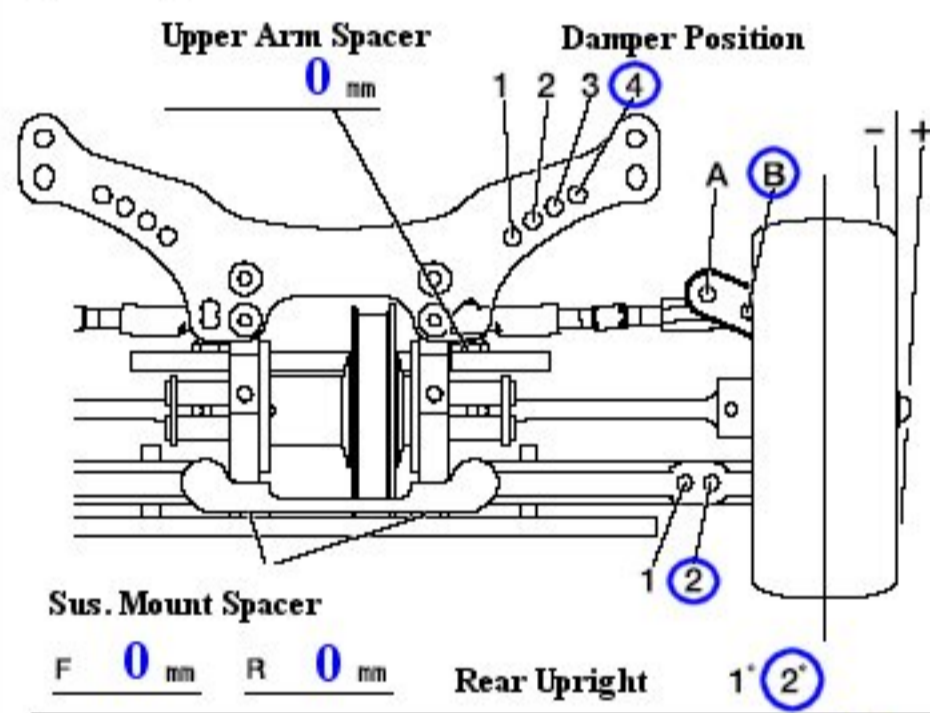

Camber	2°
Ride Height	5.5 mm
Droop	#4 mm
Roll Bar	None S M H
Centre Drive Locked	One-way
Notes	



Shock Length	62.5 mm
Piston	3 holes
Oil	50 wt.
Spring	Blue
Wheel Hex	6 mm
Wheel Spacer	0 mm

Toe Angle (Front) **0°** F Sus. Mount Front X A B **C** D Rear **A** D R Sus. Mount Front X A B **C** D Rear X A B C **D**

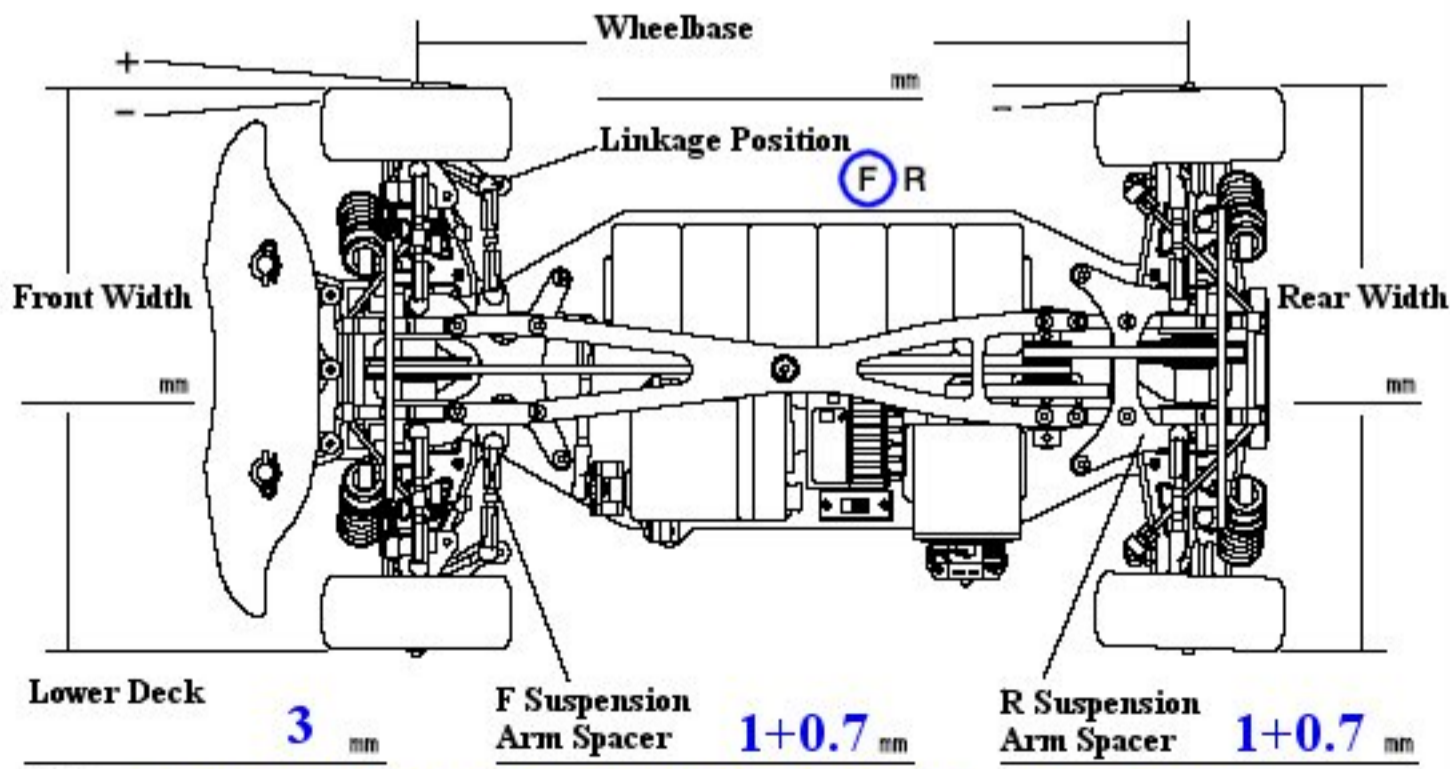

Notes **Tried soft roll bars (F&R) for finals... bad move! Large loss of grip**

Motor **EA ROAR 27t stock**
 Spur Gear **103 T** Pinion Gear **30 T**
 Battery **NRG GP3300**
 Body **P'Form Mazda6**
 Wing **Std**
 Tire **HPI 15-40**
 Wheel **HB 26mm inch-up**
 Tire Insert **JB Blue moulded**
 Best Lap _____