

# TRF415

## SETTING SHEET [Lightweight suspension]

Name **Ed Clark** Date **06-02-05** Air Temp. Humidity  
Track **Broxtowe Indoor** Track Cond. Track Temp.

### [Front]

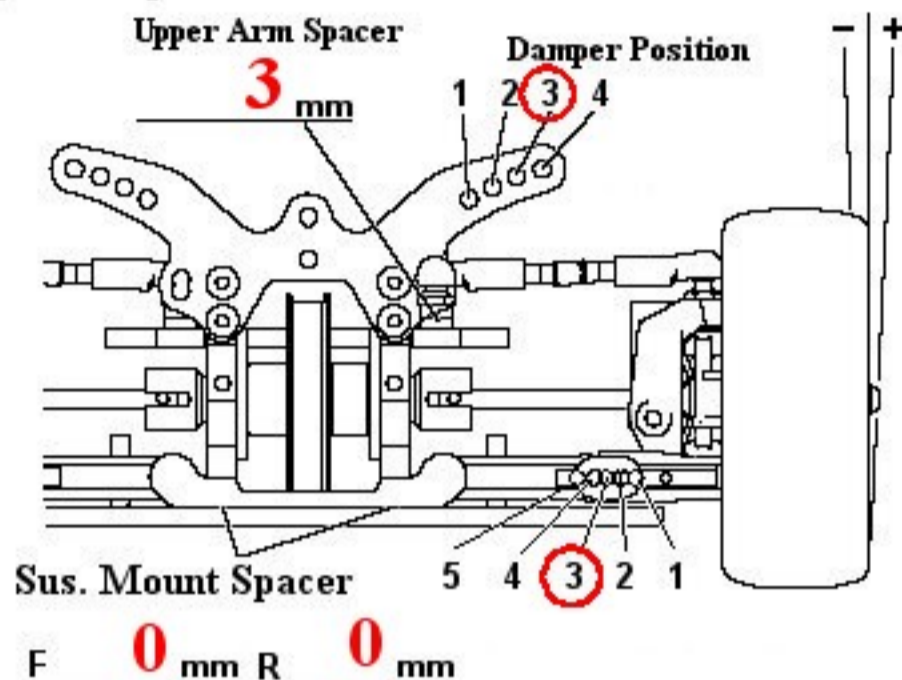

Camber **1.5** °  
Ride Height **5** mm  
Droop **#4** mm  
Front Drive **Spool** Diff One-way  
Roll Bar **None** S M H  
Caster Block 2° **4** °



Shock Length **62.0** mm  
Piston **3** holes  
Oil **50** wt.  
Spring **Tam Blue**  
Wheel Hex **6** mm  
Wheel Spacer **0** mm

Notes **MS Shock Tower**

### [Rear]

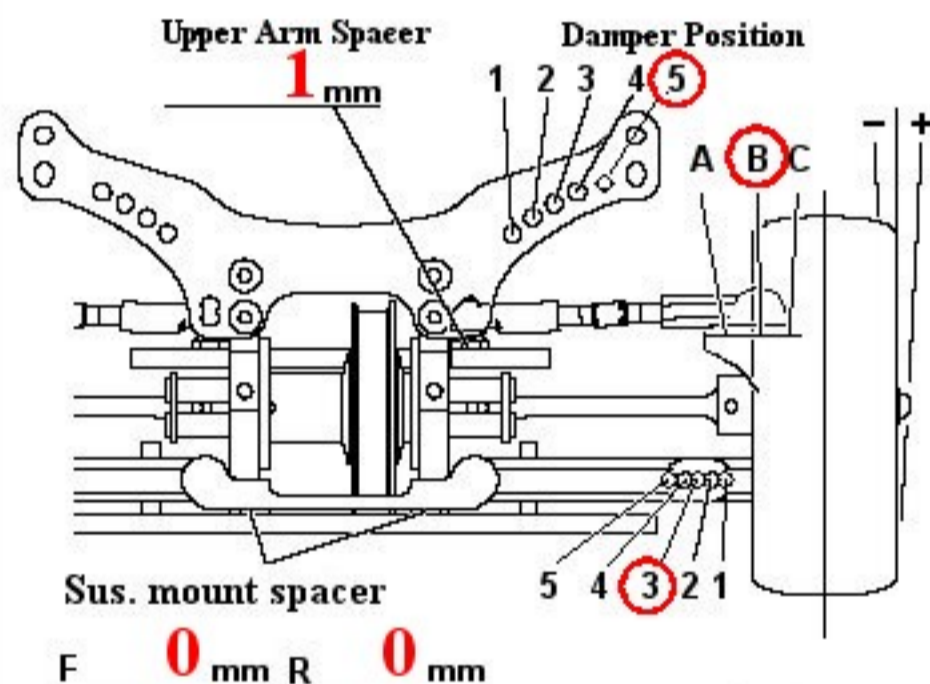

Centre Drive **Locked** One-way  
Camber **1.5** °  
Ride Height **5.5** mm  
Droop **#4** mm  
Roll Bar **None** S M H  
Outer ball joint shim **2** mm



Shock Length **62.0** mm  
Piston **3** holes  
Oil **50** wt.  
Spring **Tam Blue**  
Wheel Hex **6** mm  
Wheel Spacer **0** mm

Notes **MS Shock Tower  
0deg alloy hubs**

F Sus. Mount Front XD XC XB XA X **A** B C D E R Sus. Mount Front XD XC **XB** XA X A B C D E  
Rear XD XC XB **XA** X A B C D E Rear XD XC XB XA X **A** B C D E

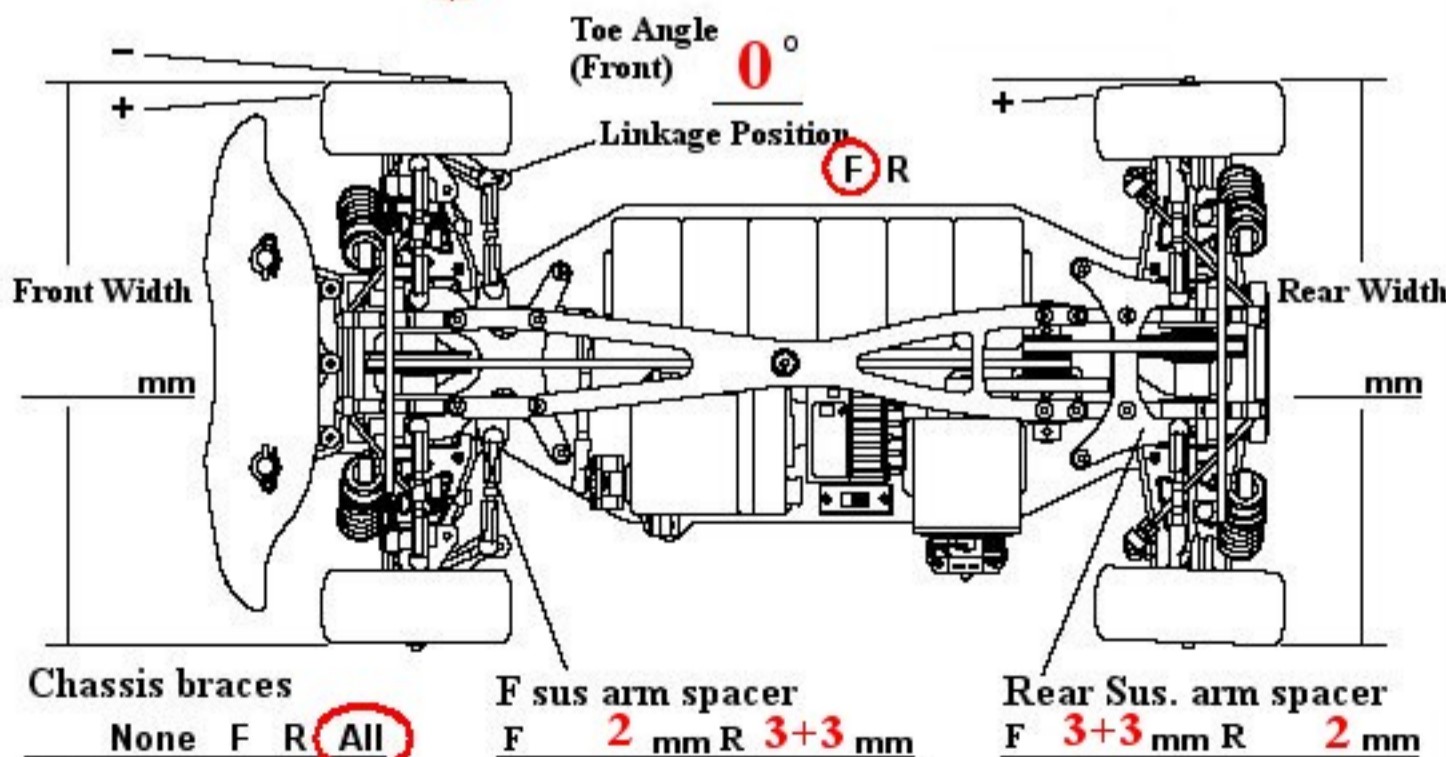

Notes **Very responsive, hard to drive when track grip low**

Motor **EA ROAR**  
Spur Gear **104** T Pinion Gear **27** T  
Battery **Promatch GP3300**  
Body **P'Form Mazda6**  
Wing **Standard +spill plates**  
Tire **Sorex 24R**  
Wheel **Yokomo 24mm**  
Tire Insert **Sorex B-Med**  
Best Lap