

TRF415

SETTING SHEET [Lightweight suspension]

Name **Ed Clark** Date **23-01-05** Air Temp. _____ Humidity _____
 Track **Ashby - BRM Rd4** Track Cond. _____ Track Temp. _____

[Front]

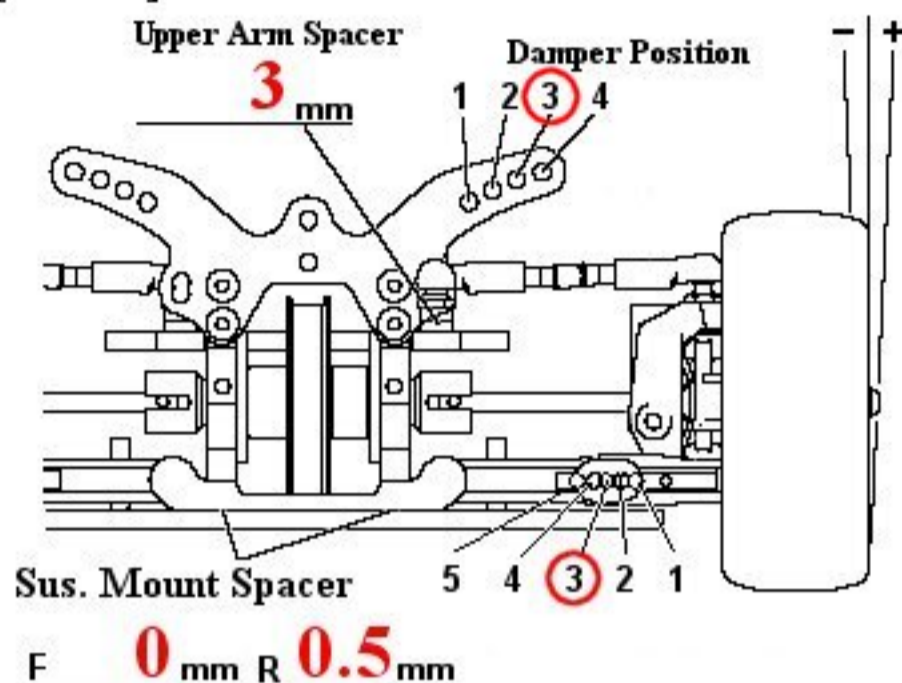

Camber **-1.5°**
 Ride Height **5 mm**
 Droop **#4 mm**
 Front Drive **Spool** Diff One-way
 Roll Bar **None** S M H
 Castor Block 2° **4°**



Shock Length **62.0 mm**
 Piston **3 holes**
 Oil **50 wt.**
 Spring **Blue**
 Wheel Hex **6 mm**
 Wheel Spacer **0 mm**

Notes
Ms Shock towers

[Rear]

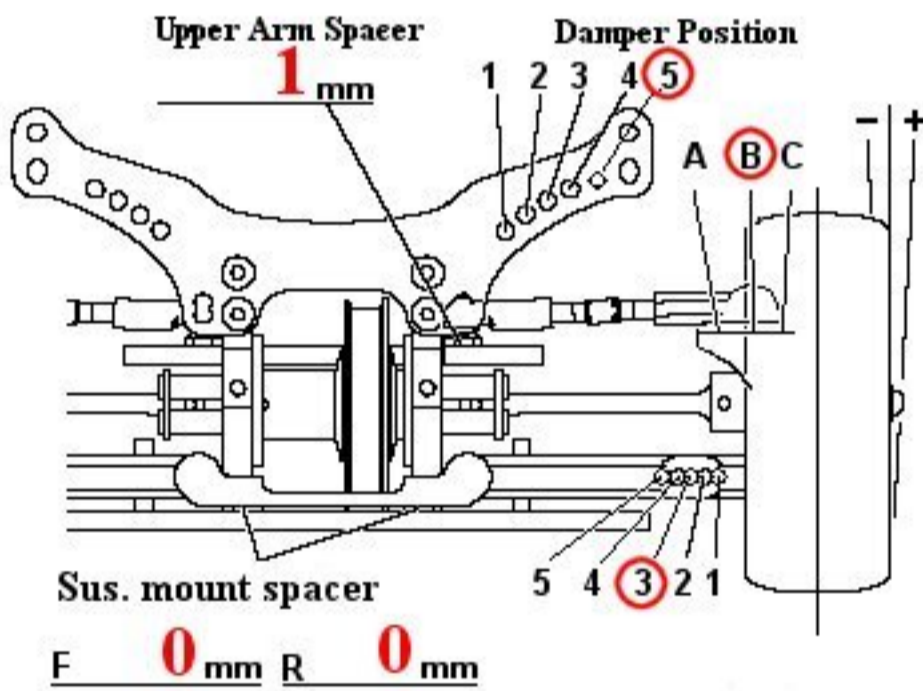

Centre Drive **Locked** One-way
 Camber **-1.5°**
 Ride Height **5.5 mm**
 Droop **#4 mm**
 Roll Bar **None** S M H
 Outer ball joint shim **0 mm**



Shock Length **62.0 mm**
 Piston **3 holes**
 Oil **50 wt.**
 Spring **Blue**
 Wheel Hex **6 mm**
 Wheel Spacer **0 mm**

Notes
Ms Shock towers

Toe Angle (Front) **0°** F Sus. Mount Front X A B C **D** Rear **A D** R Sus. Mount Front X **A** B C D Rear X A **B** C D

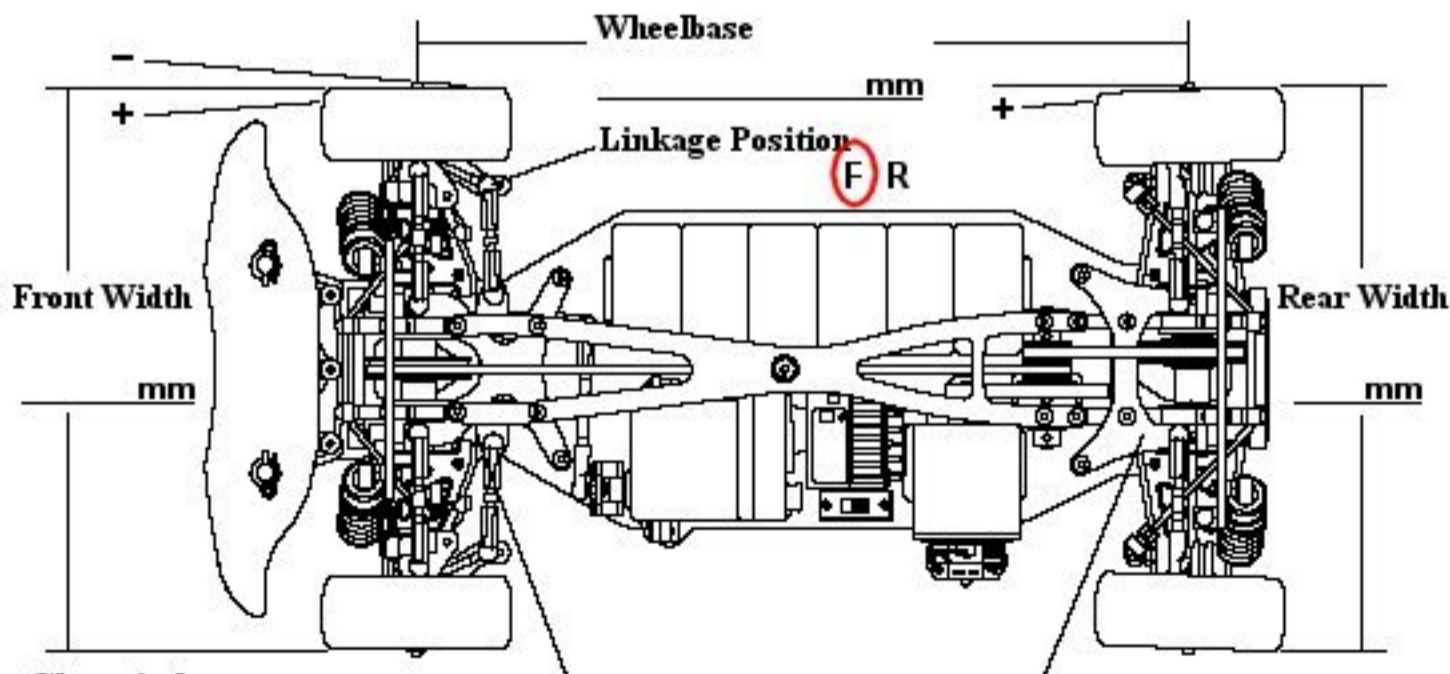

Chassis braces None F R **All** F sus arm spacer F **2 mm** R **3+3 mm** Rear Sus. arm spacer F **3+2 mm** R **3 mm**

Notes **Slightly unstable rear end in high speed turns. Car turned in almost too quick, try no pro-/anti-dive on front**

Motor **Monster**
 Spur Gear **104 T** Pinion Gear **26 T**
 Battery **NRG GP3300**
 Body **P'form CTS-V**
 Wing **Std**
 Tire **Sorex 24R**
 Wheel **Yokmo 26mm**
 Tire Insert **Sorex B-Med**
 Best Lap _____