

TRF415

SETTING SHEET [Lightweight suspension]

Name **Ed Clark** Date **24-10-04** Air Temp _____ Humidity _____
 Track **BRM Champ Rd1 - Ashby indoor** Track Condition **Carpet - Good** Track Temp _____

[Front]

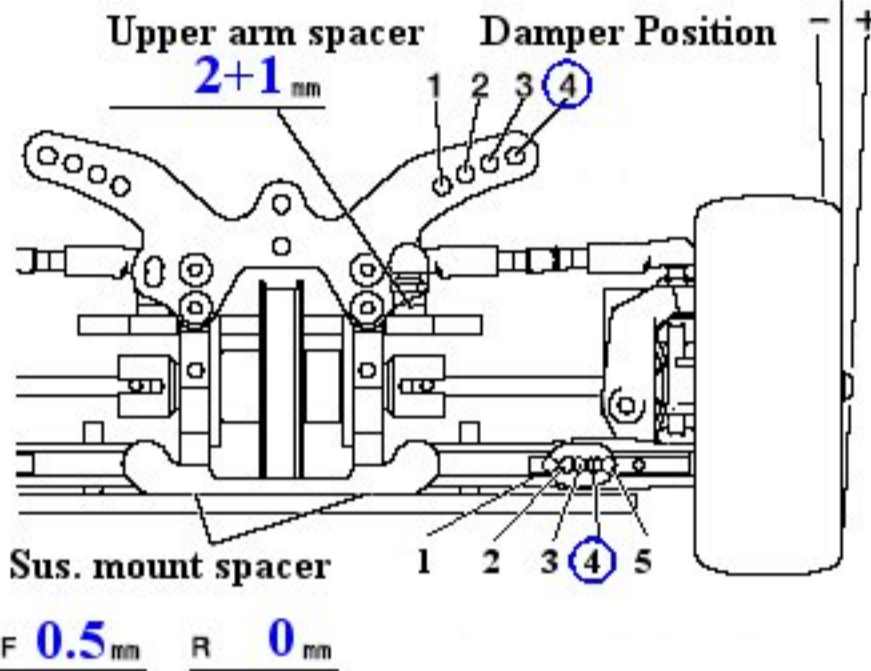

Camber Angle **1.5°**
 Ride Height **5 mm**
 Droop **#4 mm**
 Front Drive **One-way** Diff Spool
 Roll-bar **None** S M H
 Castor Block 2deg **4deg**



Shock Length **62.0 mm**
 Piston **3 holes**
 Oil **60 wt.**
 Spring **Tam White**
 Wheel Hex **6 mm**
 Wheel Spacer **0 mm**

Notes

No roll bar used as track very tight

[Rear]

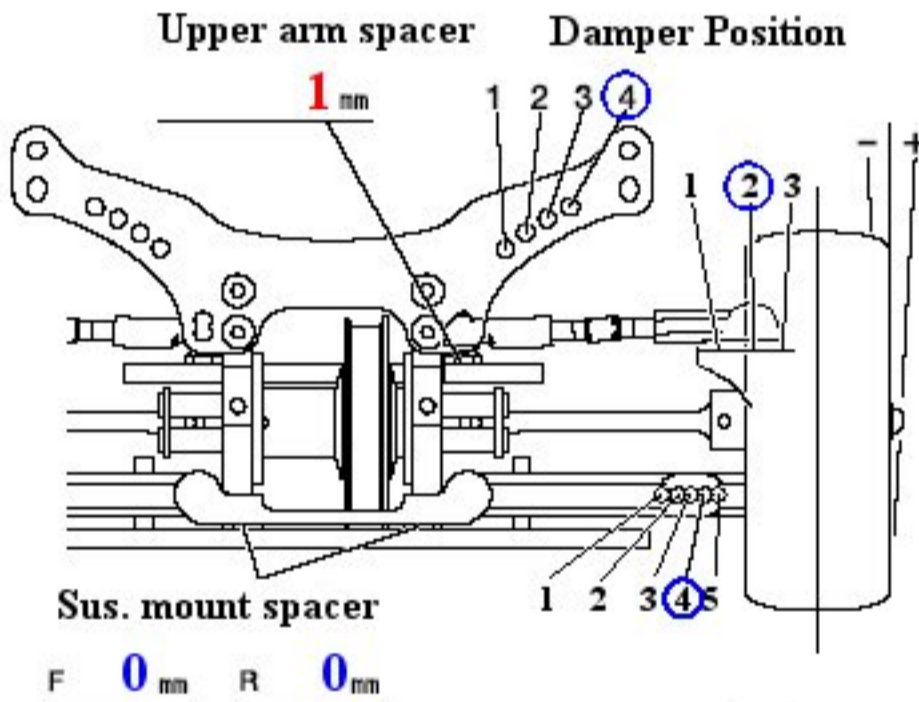

Centre drive **One-way** Fixed
 Camber Angle **1.5°**
 Ride Height **5.5 mm**
 Droop **#5 mm**
 Roll-bar **None** S M H
 Outer ball joint shim **0.5 mm**



Shock Length **62.5 mm**
 Piston **3 holes**
 Oil **60 wt.**
 Spring **Tam Blue**
 Wheel Hex **4 mm**
 Wheel Spacer **1+0.5 mm**

Notes

Raised rear roll centre, as car understeered on exit @ end of runs

Front Toe

0°

F sus. mount Front X A B **C** D
 Rear **A** D

R sus. mount Front X A **B** C D
 Rear X A B C **D**

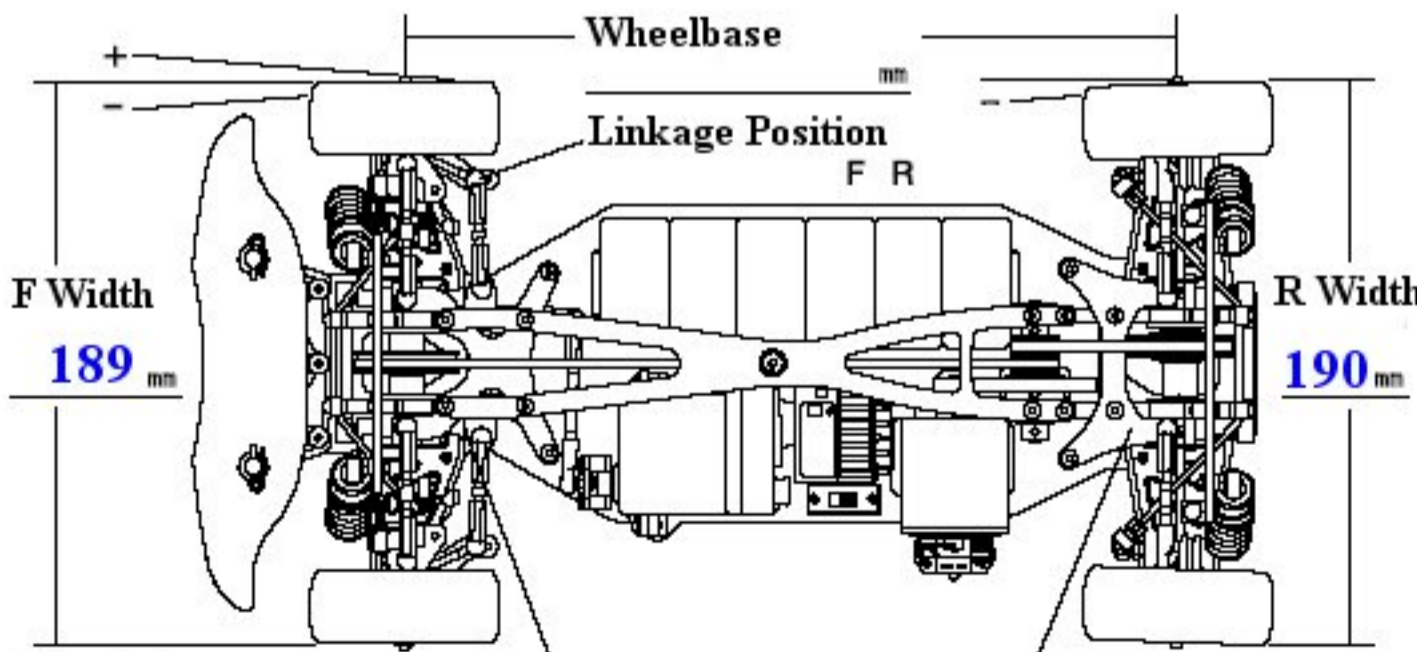

Chassis braces None F R **All**
 F sus arm spacer F **2 mm** R **3+3 mm**
 Rear Sus. arm spacer F **3+2 mm** R **3 mm**

Notes **Sub 9sec lap fastest.**

Changes from Carpet Base highlighted in red

Motor

Monster Pro 27x1

Spur **105 T** Pinion **27 T**

Battery **NRG GP3300**

Speedo **MRT VX Pro**

Body **Tam Subaru B4**

Wing **Straight Version**

Tire **Sorex 24R**

Insert **Sorex B Med (MB24M)**

Wheel **Yokomo 24mm A'dish**